

Dimensions

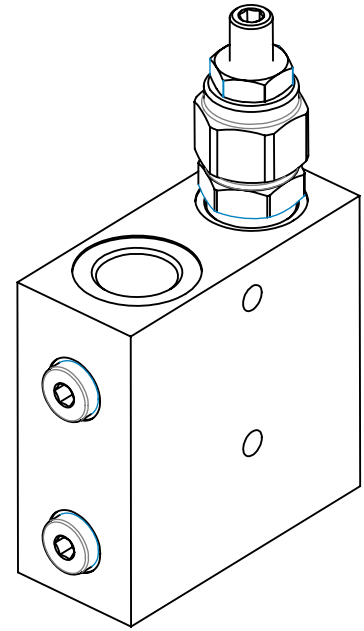

Size	A	B	C	D max	E	F	G	H	L	N BSP	R	Weight kg
02	80	35	80	51	10	40	6,5	62	42,5	3/8	22	0,72
03	80	35	80	51	10	40	6,5	62	42,5	1/2	22	0,710

Hydraulic Symbol

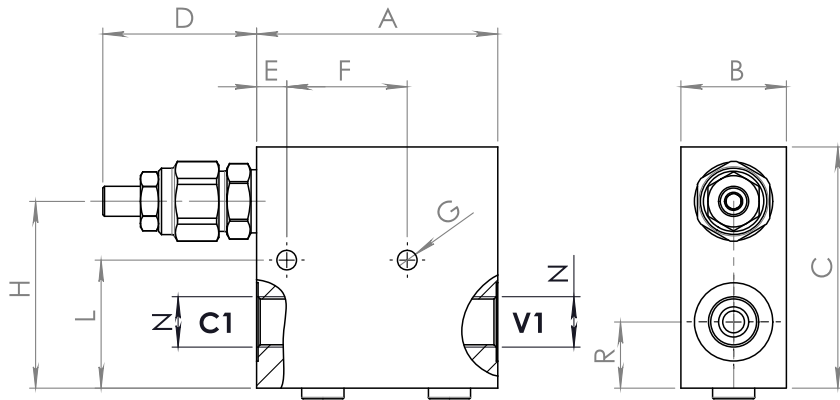
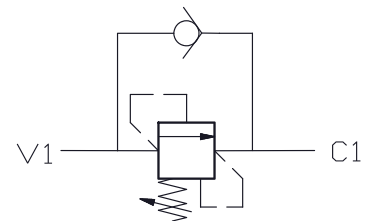

Curves

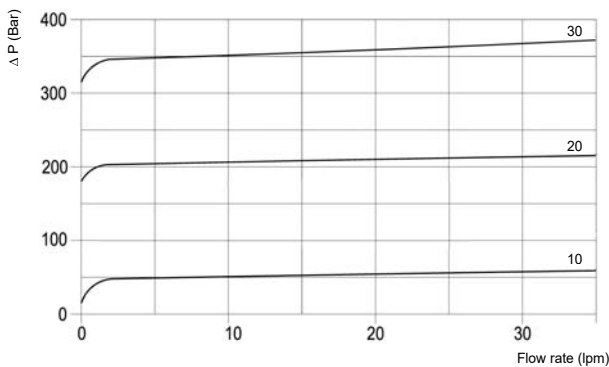

Features

Rated Flow (lpm)	35
Max Pressure (bar)	260

Materials: Zinc plated steel cartridge, hardened steel inner parts.
Aluminium manifold.

Ordering Code

SV 35 -- -- -

Port Size BSP		Spring (bar)	
02	3/8	10	5-50
03	1/2	20	40-210
		30	100-350

Adjustments

A		Socket Screw
B		Handknob
C		Tamperproof Cap

Ordering Code Example: SV350220A = 3/8 Port Size - 40-210 bar setting range, Socket screw adjustment.